

Camcarriers®

Side Loading

For GN Food Pans

Models 150MPC, 300MPC

Features & Benefits



- Rugged and dependable, these Camcarriers transport hot and cold food from kitchen to event.
- Offers a wide variety of food transporting options with GN Full and Fractional Size Food Pans. (Model 150MPC holds GN 1/2 Food Pans only).
- GN 1/2 Size Food Pans capacity:
 - Model 150MPC - 4 each 2½" (6,5 cm) deep
 - 3 each 4" (10 cm) deep
 - or 2 each 6" (15 cm) deep
- GN 1/1 Full Size Food Pans capacity:
 - Model 300MPC - 4 each 2½" (6,5 cm) deep
 - 3 each 4" (10 cm) deep
 - or 2 each 6" (15 cm) deep
- Store hot and cold foods in the same compartment with the use of the optional ThermoBarrier® Insulated Shelf Divider. Keep food chilled for 8 hours or more with the optional Camchiller®. (Available for Model 300MPC only.) No external power or ice required. Maintain safe temperatures for hot food with the optional Camwarmer™.
- One piece seamless, double-wall, high-density polyethylene construction is durable, lightweight and dishwasher safe. Textured exterior is scratch resistant.
- Foamed-in polyethylene insulation and an airtight gasket helps to ensure excellent food temperature retention, hot or cold. Recessed vent cap located on the door helps equalize pressure and release steam.
- Two each recessed plastic latches secure the door tightly and will not rust or corrode.
- Molded-in handles provide comfortable, easy transporting.
- Securely stacks easily for more efficient transportation and storage.
- Optional Camdollies® provide easy transporting. (Not available for Model 150MPC).
- Non-electrical.
- No assembly required.
- Available in 10 colors.

Item No. _____

Specifier Identification No. _____

Model No. _____

Quantity _____



"Camcarriers Keep Food Hot for Hours!"

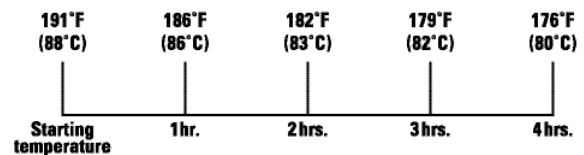

"Camcarriers Keep Food Cold for Hours!"

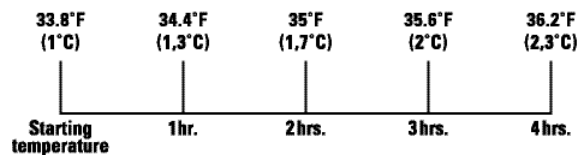

Approvals



Camcarriers®

Side Loading

For GN Food Pans

Models 150MPC, 300MPC

Item No. _____

Specifier Identification No. _____

Model No. _____

Quantity _____

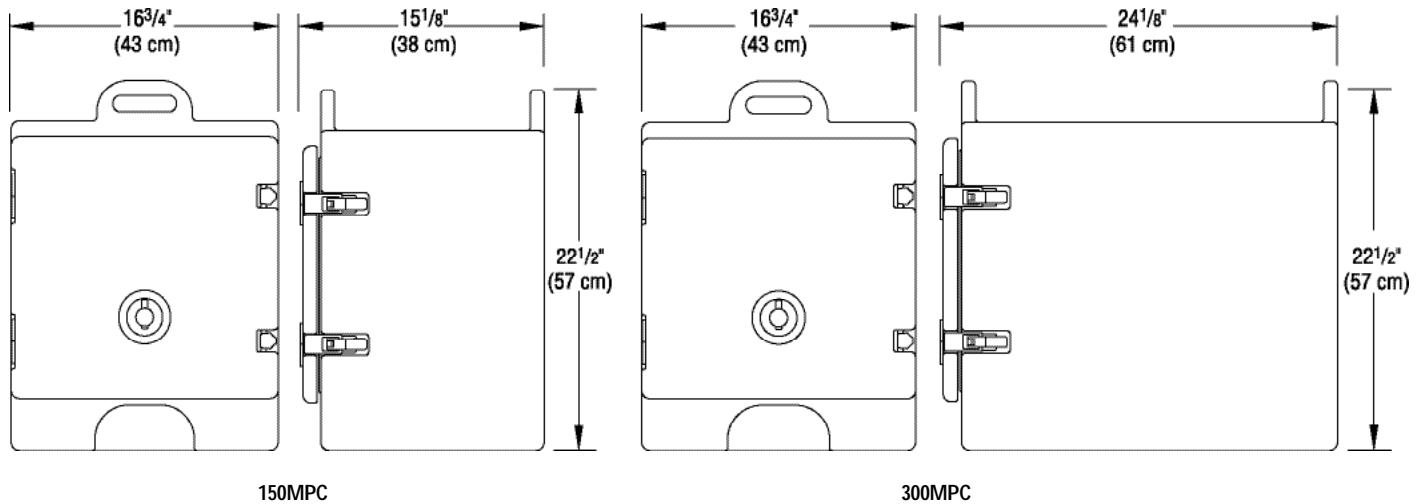

Specifications

Dimension Tolerance: +/- 1/4" (0,64 cm)

Code	Description	Approx. Capacity	Exterior Dimensions W x D x H	Case lbs./cube Kg/m ³
150MPC	Camcarrier	17.4 qts (16.5 L)	16 3/4" x 15 1/8" x 22 1/2" (43 x 38 x 57 cm)	21.5 (3.66) 10 (0,1)
300MPC	Camcarrier	36 qts (34 L)	16 3/4" x 24 1/8" x 22 1/2" (43 x 61 x 57 cm)	31.5 (5.74) 14,5 (0,16)

Optional Accessories

- ThermoBarriers®
 - 300DIV for 300MPC
 - Coffee Beige (157)
- Camchiller®
 - CP1220 for 300MPC
 - Cold Blue (159)
- Camwarmer™
 - 1210PW for 300MPC & 150MPC
 - Granite Gray (191)
- Camdolly®
 - CD300 for 300MPC
 - CD300H for 300MPC
 - CD300HB for 300MPC

Standard Colors

- Dusty Rose (400)
- Navy Blue (186)
- Slate Blue (401)
- Cold Blue (159)
- Coffee Beige (157)
- Dark Brown (131)
- Brick Red (402)
- Green (519)
- Black (110)
- Hot Red (158)

Architect Specs

The portable non-electrical side loading GN Food Pan transport carriers shall be Camcarriers, Models 150MPC and 300MPC, manufactured by Cambro Mfg. Co., Huntington Beach, CA 92648 U.S.A. It shall be made of one-piece, seamless, double-wall, high-density polyethylene and foam-injected polyurethane. It shall have a recessed vent cap on the outside side compartment door to help equalize pressure and release steam. It shall have an airtight gasket. It shall be available to transport GN Full and Fractional size Food Pans, up to 6" (15 cm) deep. It shall be available to accommodate an optional ThermoBarrier shelf divider or Camchiller. It shall have 2 each recessed plastic latches. It shall have two each molded-in handles. It shall have an interlock design on the bottom and top corners to provide secure stacking for transport and storage. It shall be available for transport with optional Camdollies. It shall require no assembly and shall be available in 10 colors.

Approvals

